

37' and 42'
truss style derrick
Min. diameter 16"
Max. diameter 115"

Rig painted to
customer specs

Pull-out arm
raised by derrick

Choice of power unit or
truck's transfer case

Deck mounted fuel
and hydraulic tank

51"
turntable

4 point outriggers system

(Customizing & other options obtainable.)

SUPER GEORGE BUCKET AUGER



1480 Lincoln Street SW
 PO Box 96 • Le Mars, Iowa 51031
 712.546.4145 • 800.383.7324
 Fax: 712.546.8945
 guspech@guspech.com

MODEL	KELLY	TURNTABLE	SPEED	TORQUE
H-51	4-scope, 100' (std)	51" opening	0-24 rpm	31,090 ft lb
H-51	4-scope, 120' (std)	51" opening	0-24 rpm	31,090 ft lb
HDH-51	4-scope 120' (std)	51" opening	0-24 rpm	41,000 ft lb
HDH-51	5-scope, 150' (opt)	51" opening	0-24 rpm	41,000 ft lb

FEATURES

- 16" - 115" boring capabilities
- 3 1/2" main square bar (H models)
- 4" main square bar (HDH models)
- 37' truss derrick
- 4 point hydraulic outrigger system
- Hydraulic system with hydraulic cooler
- Pull-out arm with telescoping platform anchor, automatically positioned by raising derrick
- Operator control console with overhead guard
- Transfer case from truck engine or diesel power unit
- 14,000 lb auxiliary winch (5/8" or 3/4" cable)
- 14,000 lb Kelly winch (3/4" cable) with cable tensioner (H models)
- 18,000 lb Kelly winch (7/8" cable) with cable tensioner (HDH models)



OPTIONS

- 42' truss derrick
- 120' and 150' Kelly systems
- Derrick hydraulic Kelly pushout
- Hinged swing-around derrick head
- Kelly bar crowd/pulldown attachment
- Encased outriggers
- Water piping system
- Extension rod system for drilling up to 200 feet
- Hydraulic hose reel
- Tool and storage compartments
- Night working lights
- Hydraulic or mechanical orange peel buckets
- All sizes of drill buckets and tooling
- Reamers for boring larger than bucket diameter

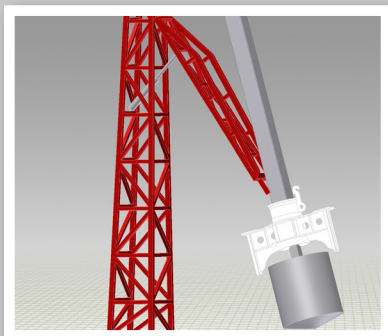

Derrick hydraulic Kelly pushout

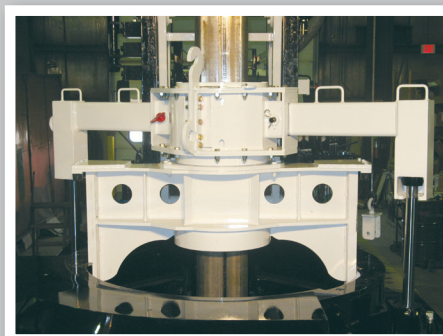

Pull down assembly



51" heavy duty turntable

Tandem axle truck, trailer, skid, or track mounted • Customizing obtainable